

# AIR NEEDLE SCALER

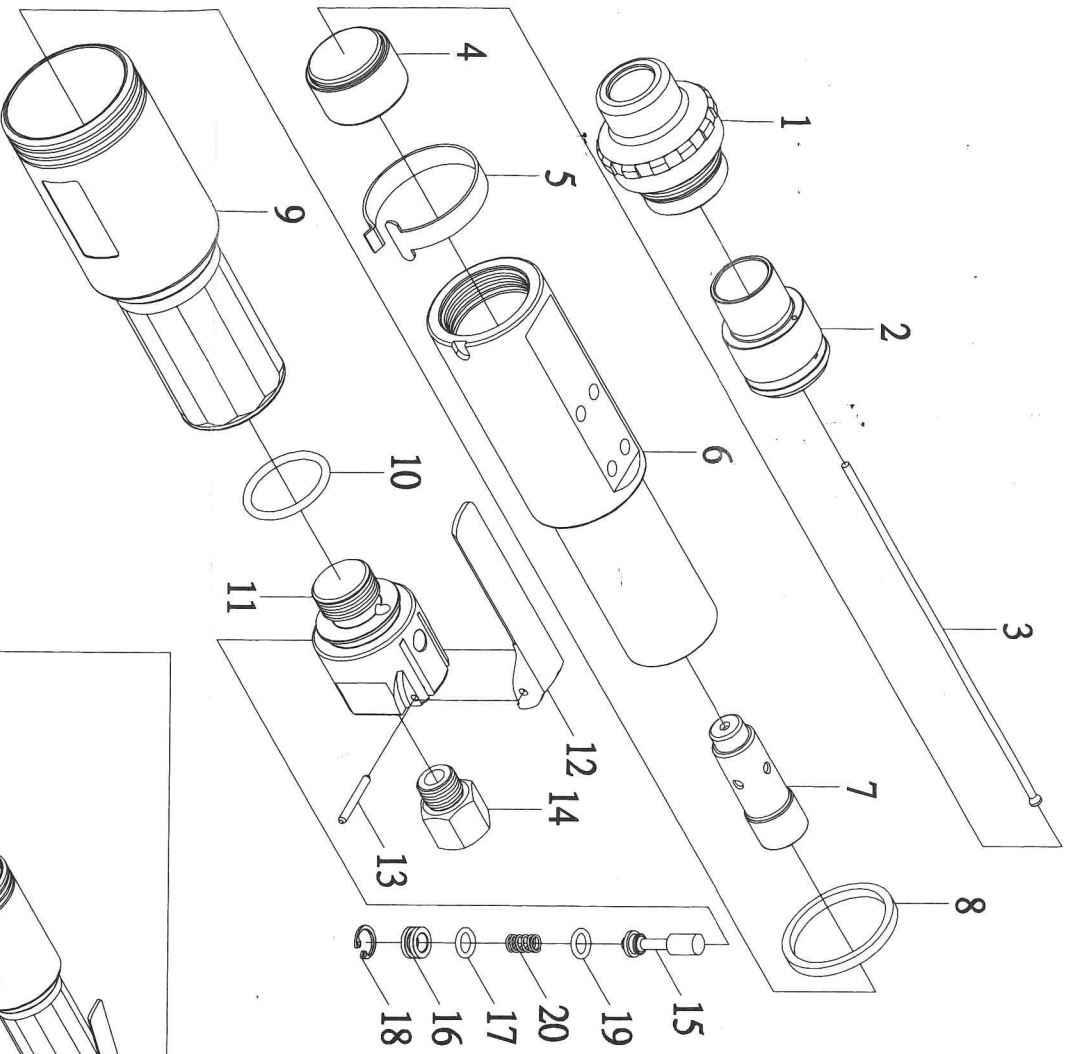

**SPECIFICATION:**

\*BLOW PER MINUTE-----4000 BPM \*PISTON SIZE (mm)-----18x20

\*AIR CONS-----7.1 CFM \*WEIGHT-----2.4 KG

\*AIR PRESSURE-----90 PSI \*AIR INLET-----3/8"PT(NPT)

\*HOSE SIZE-----3/8"ID

| REF. NO. | PART NO. | DESCRIPTION                | QTY | REF. NO. | PART NO. | DESCRIPTION              | QTY |
|----------|----------|----------------------------|-----|----------|----------|--------------------------|-----|
| 1        | 020001   | LOCK RING                  | 1   | 11       | 020011   | VALVE BODY               | 1   |
| 2        | 020002   | 3mm NEEDLE SUPPORTER       | 1   | 12       | 020012   | THROTTLE LEVER           | 1   |
| 3        | 020003   | 3mm NEEDLE SET (Ø3x180L)   | 12  | 13       | 020013   | SPRING PIN (Ø3x24L)      | 1   |
| 4        | 020004   | THROTTLE ANVIL             | 1   | 14       | 020014   | BUSHING M16xPT3/8        | 1   |
| 5        | 020005   | SAFETY BAND                | 1   | 15       | 020015   | THROTTLE VALVE           | 1   |
| 6        | 020006   | CYLINDER                   | 1   | 16       | 020016   | SPRING SEAT              | 1   |
| 7        | 020007   | PISTON                     | 1   | 17       | 020017   | *O RING (d7.8xw1.9) (P8) | 1   |
| 8        | 020008   | STOPPER                    | 1   | 18       | 020018   | RETAINER RING C-12       | 1   |
| 9        | 020009   | COVER                      | 1   | 19       | 020019   | *O RING (d4.8xw1.9) (P5) | 1   |
| 10       | 020010   | *O RING (d29.4xw3.1) (G30) | 1   | 20       | 020020   | SPRING                   | 1   |